

S:\NPD\VL760\VL760 GUARDING ASSY\LAYOUT DRAWING\ - VL760 - FULL GUARD ASSY FOR LAYOUT

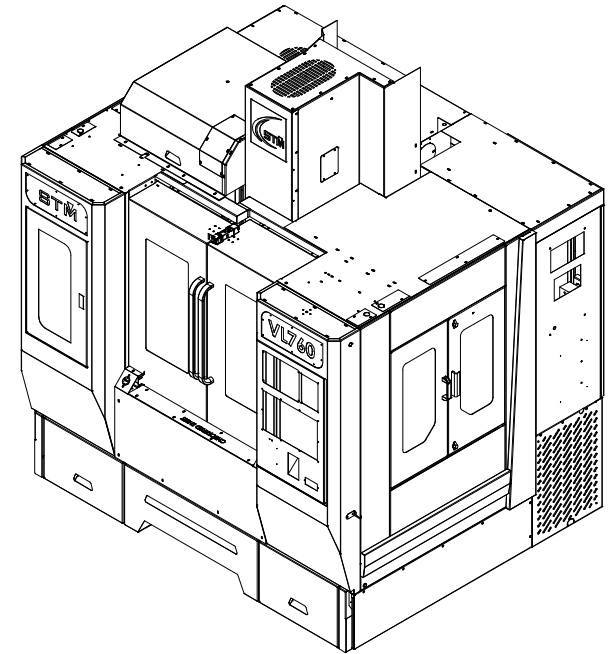

GENERAL TOLERANCE WHEREAS NOT SPECIFIED															
DIMENSION	TOLERANCE														
UP TO 6	+0.05														
6 TO 30	+0.1														
30 TO 120	+0.15	QTY	ASSY. NO.	DATE	ALTERATION DETAIL		CODE	SIGN							
120 TO 315	+0.2	QTY PER MACHINE		ALL DIMENSIONS ARE IN mm (DO NOT SCALE THE DRAWING IF IN DOUBT PLEASE ASK)											
315 TO 1000	+0.3														
1000 TO 2000	+0.5	MATERIAL	WEIGHT (KGS)	OVERALL SIZE		DESCRIPTION									
		DRAWN	RK	06.03.25	SCALE	PROJECTION		VL760-LAYOUT DRAWING							
		CHECKED			NIS	[Symbol]									
		APPROVED	PR	06.03.25					DRAWING NO.		REV. NO.	SHEET 1 OF 1			
												SHEET SIZE A2			

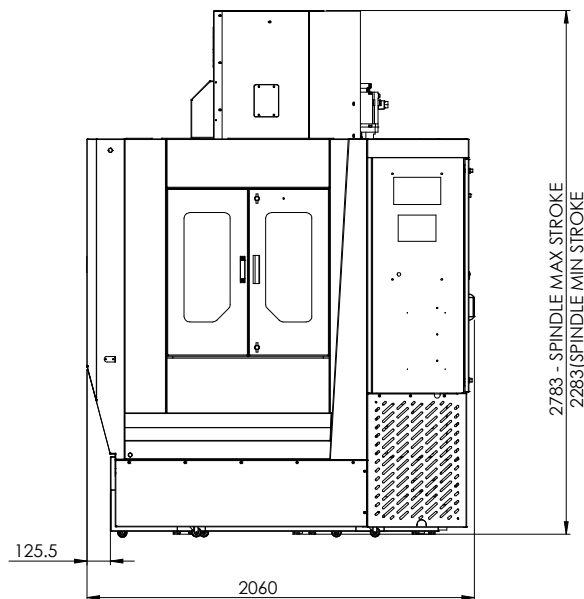
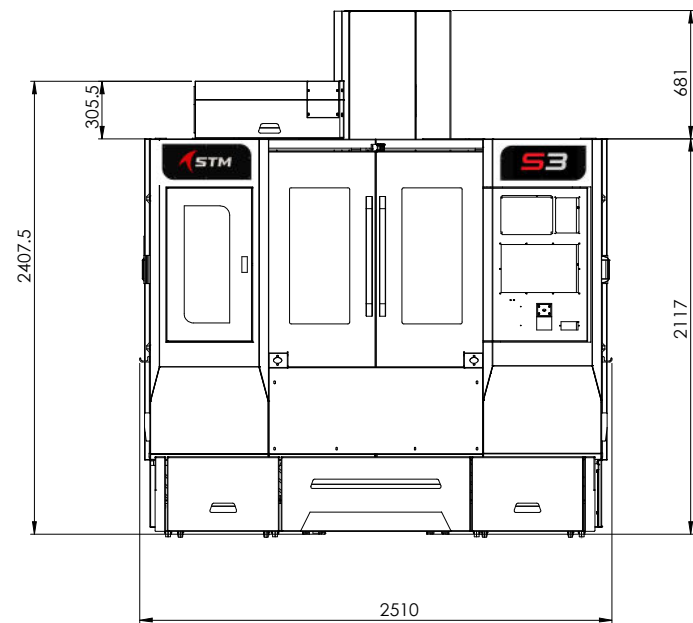
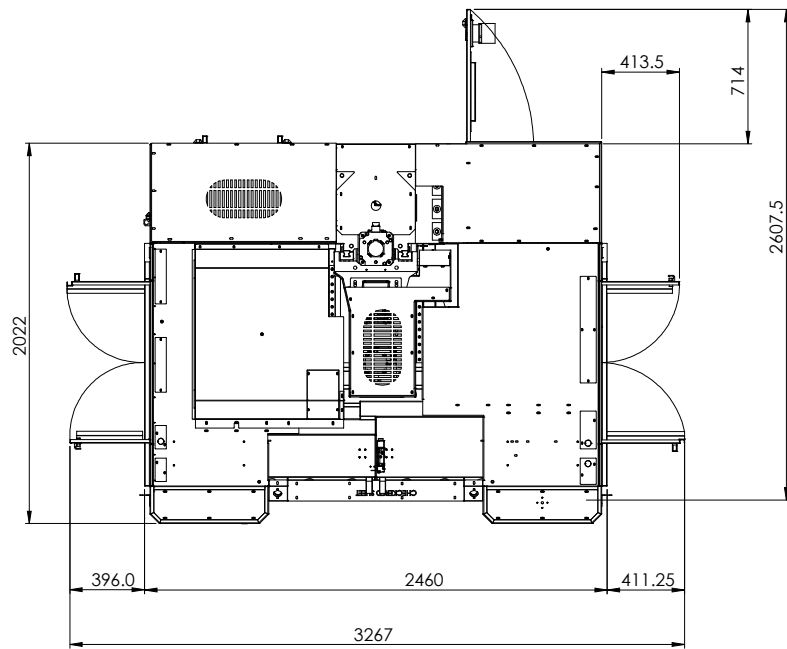

**S&T MACHINERY (P) Ltd.**  
COIMBATORE

DRAWING NO. \_\_\_\_\_  
REV. NO. \_\_\_\_\_  
SHEET 1 OF 1  
SHEET SIZE  
A2